

## DATA SHEET - REMOTE CONTROLLED CONCRETE BUCKET WITH RUBBER HOSE

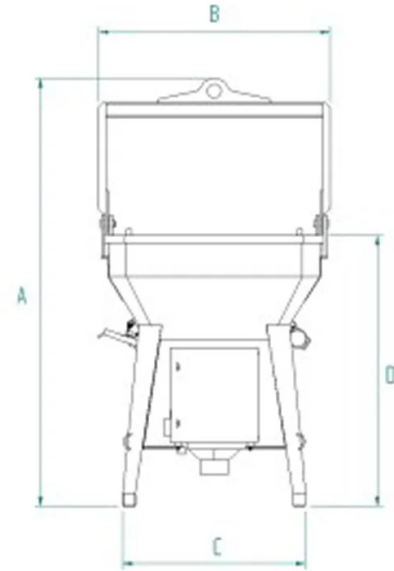

Code	Capacity (kg)	Capacity (L)	Weight (kg)	Dimensions (mm)			
				A	B	C	D
BCE-80R	2080	800	495	2710	1360	1200	1615
BCE-99R	2600	1000	595	2807	1360	1200	1712
BCE-125R	3250	1250	640	2908	1360	1200	1885
BCE-150R	3900	1500	725	3048	1560	1300	1925
BCE-175R	4550	1750	735	3170	1560	1300	2020
BCE-200R	5200	2000	750	3258	1560	1300	2135
BCE-250R	6500	2500	880	2008	1695	1700	1927
BCE-300R	7800	3000	930	2183	1695	1700	2102

## DATA SHEET - REMOTE CONTROLLED CONCRETE BUCKET WITH RUBBER HOSE

Concrete buckets



### Remote controlled concrete bucket with rubber hose

#### Octagonal concrete bucket with rubber hose and remote-controlled opening

Explore the BCE-R model, an octagonal concrete bucket equipped with a central discharge and a guillotine valve controlled via radio remote. This model is commonly used in large construction sites and in the prefabrication sector. The bucket comes with a 2-meter rubber hose, with a diameter of 200 mm (other sizes available upon request), to allow controlled and safe pouring. It features a 4-button radio remote that enables opening, closing the valve, and activating the vibrator, with a range of up to 100 meters. A unique safety feature is the automatic valve closure function in case of battery depletion, effectively preventing any unintended concrete leaks. Available in various sizes and capacities, the BCE-R model can be customized to meet specific customer needs. Customization options include lowered edge height, provision for forklift handling, and modified lifting attachments. All our buckets are built and tested according to stringent quality and safety standards, ensuring compliance with UNI EN ISO 12100, UNI EN 13854, ISO 8686, UNI EN 10027, and UNI EN 10204 regulations. Each unit is accompanied by a metal ID plate, conformity certificate, and user manual. Furthermore, all our products are covered by a one-year warranty, in compliance with the European Directive, and are constructed with certified materials to ensure durability and safety, meeting the required quality standards in the construction industry.

#### Application sectors

 Construction