

DATA SHEET - GOODS LIFTING CAGE WITH RAMP

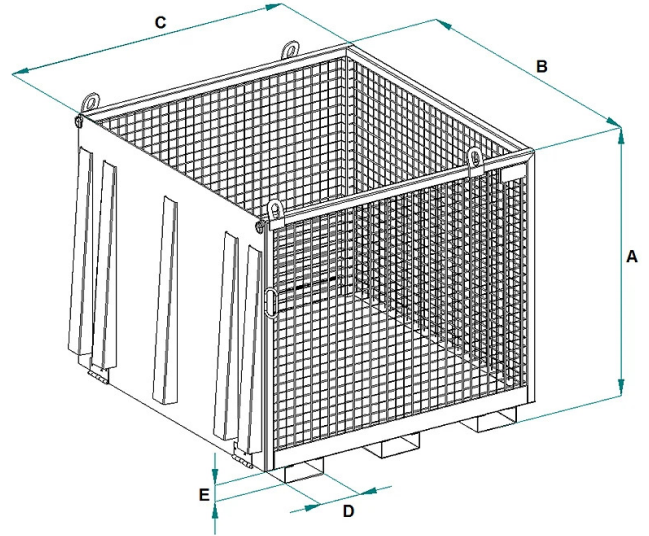

Code	Capacity (kg)	Weight (kg)	Dimensions (mm)				
			A	B	C	D	E
CST-D	2000	200	1154	1346	1360	180	65
CST-D25.20.10	1000	555	1000	2000	2500	180	65

DATA SHEET - GOODS LIFTING CAGE WITH RAMP

Storage and handling equipment



Goods lifting cage with ramp

Goods lifting cage for handling material

Introducing our goods lifting cage with ramp, a versatile accessory designed to facilitate safe lifting of materials and equipment on construction sites and in industrial environments. This basket is equipped with a sturdy ramp, providing easy access for loading and unloading pallets with a forklift or manual pallet jack. The robust structure and four lifting points on the sides ensure stability during handling and ensure a secure connection with the lifting device. Key features: **Integrated Ramp:** The ramp allows easy access to the basket, simplifying the loading and unloading process. **Robust Structure:** Built with high-quality materials, the basket is designed to ensure stability and durability over time. **Secure Attachment Points:** The four solid attachment points on the sides ensure a secure connection with the lifting device, reducing the risk of unwanted movements. **Versatility:** Ideal for safely and efficiently lifting materials and equipment in various work environments. Upon request, it is available in different sizes and capacities, as well as in a hot-dip galvanized version. This product is built and tested according to UNI EN ISO 12100, UNI EN 10027-1, and UNI EN 10204 standards and is issued with the appropriate metal ID plate, certificate of conformity. All our products are covered by a one-year warranty (European Directive).

Application sectors

 Construction