

DATA SHEET - FORK MOUNTED CRANE JIB

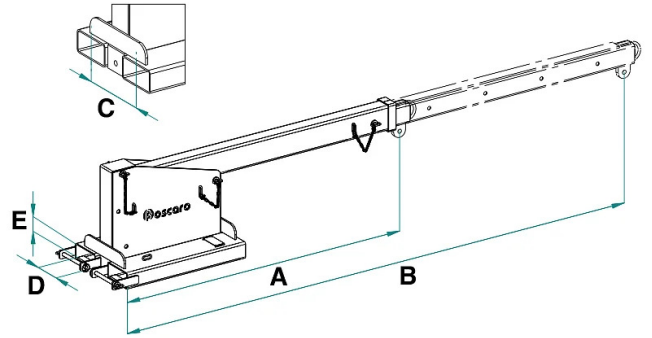

Code	Weight (kg)	Dimensions (mm)				
		A	B	C	D	E
BGM-3	205	700	3500	325	188	78
BGM-4.5	205	700	3530	325	188	78

DATA SHEET - FORK MOUNTED CRANE JIB

Warehousing logistics



Fork mounted crane jib

Adjustable and tilting crane jib for forklift

The adjustable and tilting crane jib for forklift is the ideal solution to expand the versatility of your forklift and turn it into an efficient mobile crane. Designed for safe and precise lifting operations, this attachment allows you to handle loads up to 4500 kg.

Perfect for industrial environments, construction sites, and logistics warehouses, the crane jib enables you to reach high or distant points, improving productivity without the need to invest in additional machinery.

Main features:

- Durable steel structure for maximum strength and long-lasting performance.
- Telescopic extension from 700 mm to 3,530 mm, adaptable to every lifting requirement.
- N. 3 possible operating angles: horizontal position (0°), 20° upward and 40° upward.
- 360° swivel hook and locking pin to safely secure the desired length.
- Quick installation: easily mounts on forklift forks without structural modifications.
- Universal compatibility with most industrial forklift models.

The adjustable and tilting crane jib is an efficient solution to increase the versatility and performance of your forklift in any operational context. In just a few minutes, it can transform the forklift into a full-fledged crane, expanding handling possibilities and reducing the need for additional machinery. Using this attachment helps contain operating costs, optimize investments, and make the most of existing equipment.

Its solid structure and integrated safety systems guarantee stability and reliability even when lifting heavy loads, providing maximum protection for both the operator and the handled materials. The crane jib is therefore an indispensable accessory for anyone looking to enhance their forklift's functionality with a safe, practical, and durable solution.

Application sectors

 Industry