

## DATA SHEET - HOIST CIRCULAR TIPPING BUCKET

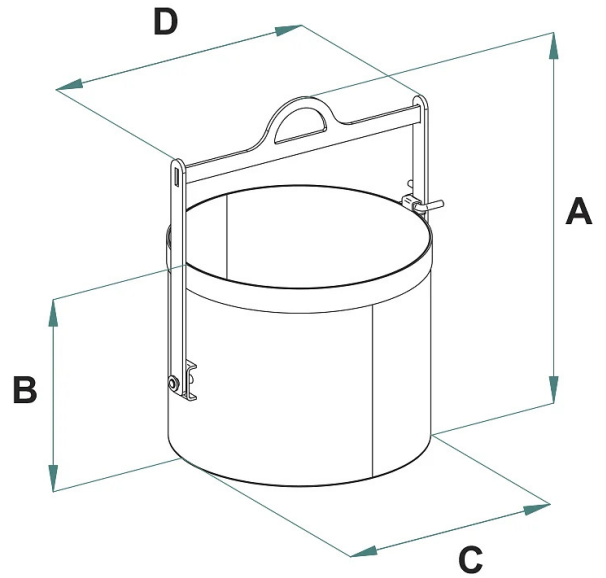

Code	Capacity (kg)	Capacity (L)	Weight (kg)	Dimensions (mm)			
				A	B	C	D
BTB-045	90	45	14	600	362	400	463
BTB-06	120	60	16	637	380	450	513
BTB-08	160	80	20	697	410	500	563

## DATA SHEET - HOIST CIRCULAR TIPPING BUCKET

---

Self dumping bins



### Hoist circular tipping bucket

#### Cylindrical tilting bucket

Our cylindrical tilting bucket, with a maximum capacity of up to 160 kg and a tare weight of 20 kg, is the ideal accessory for jib cranes or cranes with limited capacity. This model proves particularly effective in confined spaces and for handling small loads on construction sites. The bucket's watertight seal makes it suitable for loading liquids, ensuring safety against potential leaks. Made from high-quality materials, the tilting bucket offers excellent resistance to impacts and abrasions, ensuring long-term durability. All our buckets are built and tested according to UNI EN ISO 12100, UNI EN 13854, ISO 8686, UNI EN 10027, and UNI EN 10204 standards. Each unit comes with a dedicated metal ID plate, a certificate of conformity, and a comprehensive user and maintenance manual to ensure optimal use. Additionally, all our products are covered by a one-year warranty in accordance with European directives, offering peace of mind and long-term satisfaction.

#### Application sectors

 Construction