

DATA SHEET - SELF BALANCING CRANE FORK EQUIPPED WITH 4 FORKS

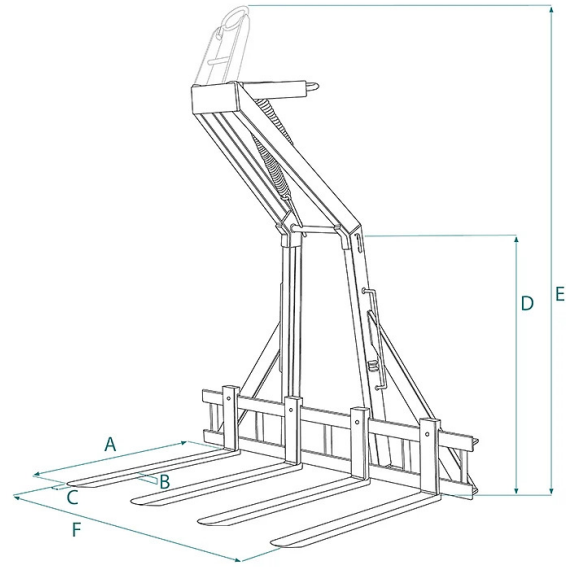

Code	Capacity (kg)	Weight (kg)	Dimensions (mm)					
			A	B	C	D	E	F
ITA-20D4	2000	270	1000	30	90	1250	2500	1800

DATA SHEET - SELF BALANCING CRANE FORK EQUIPPED WITH 4 FORKS

Crane forks



Self balancing crane fork equipped with 4 forks

Crane fork with automatic spring balancing for double pallet

The crane fork is designed with four adjustable tines, providing the necessary flexibility to lift two pallets side by side simultaneously. The automatic spring balancing allows for quick and direct load balancing with both truck-mounted cranes and construction site cranes. Its versatility, with adjustable tines and automatic balancing, makes it ideal for those looking to save time handling brick packages on construction sites or in production areas. All our crane forks are built and tested according to UNI EN 13155, UNI EN ISO 12100, UNI EN 13854, ISO 8686, and UNI EN 10204 standards. They are supplied with the appropriate metal ID plate, certificate of conformity, and user and maintenance manual. All our products are covered by a one-year warranty (European Directive).

Application sectors

 Construction  Lifting