

DATA SHEET - SELF DUMPING BIN

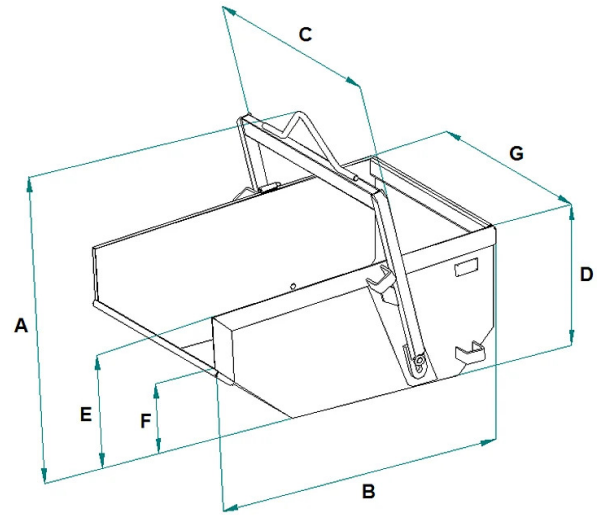

Code	Capacity (kg)	Capacity (L)	Weight (kg)	Dimensions (mm)						
				A	B	C	D	E	F	G
A-20D	400	200	60	800	1000	850	480	370	250	780
A-30D	600	300	65	980	1180	850	540	460	350	780
A-35D	700	350	70	980	1180	950	540	460	350	880
A-40D	800	400	75	980	1180	1050	540	460	350	980
A-50D	1000	500	80	1080	1280	1050	600	500	380	980
A-60D	1200	600	95	1080	1280	1150	600	500	380	1080
A-80D	1600	800	130	1240	1520	1160	760	620	350	1080
A-99D	2000	1000	185	1360	1680	1380	860	660	400	1280
A-150D	3000	1500	215	1370	1700	1430	860	860	640	1340
A-99DR	2000	1000	235	1358	1694	1266	769	665	377	1118
A-150DR	3000	1500	310	1472	1787	1278	904	805	485	1108
A-200D	4000	2000	565	1518	1970	1612	946	840	530	1412
A-300D	6000	3000	670	1625	2146	1962	1006	900	580	1762
A-400D	8000	4000	1150	2036	2551	2268	1130	1011	710	2062
A-600D	12000	6000	1800	2416	2830	2272	1436	1330	880	2066



DATA SHEET - SELF DUMPING BIN

Code	Capacity (kg)	Capacity (L)	Weight (kg)	Dimensions (mm)						
				A	B	C	D	E	F	G
A-800D	16000	8000	3000	2743	3425	2269	1736	1610	1072	2066
A-1000D	20000	10000	4100	3007	4021	2269	1858	1710	1163	2066
A-1500D	30000	15000	5910	3280	4022	3500	1879	1731	1185	3150



DATA SHEET - SELF DUMPING BIN

Self dumping bins



Self dumping bin

Self dumping bin for general muck, rubble and waste removal

The A-D model is our most requested automatic discharge bucket for cranes on the market. Its distinctive feature is the absence of the need for manual intervention during discharge, thanks to the innovative tipping mechanism activated by a bale arm, which houses two practical side 'lock-unlock' systems. The discharge process is very intuitive: simply rotate the lifting arm backward and then pull it upwards to easily tip the bucket and allow material discharge. Subsequently, the reverse operation returns the bucket to a horizontal position, ready to be safely lifted and refilled. This bucket is designed to facilitate the handling of a wide range of construction materials, including sand, gravel, debris, waste, and much more. To meet various market needs, we offer the A-D model also in galvanized and aluminum versions, ensuring maximum strength, versatility, and durability in various conditions and work contexts. The range of available sizes is extremely wide, from 200 liters to 15,000 liters, allowing a precise choice based on your project's specific needs. Some features:

- Versatility of use:** The A-D bucket is extremely versatile and can be used for a wide range of materials, including sand, gravel, demolition debris, rubble, soil, and much more.
- Safety:** Thanks to its automatic discharge design, this bucket minimizes the risk of accidents due to manual intervention in the discharge area, greatly improving workplace safety.
- Durability and strength:** Made with high-quality materials and produced according to strict manufacturing standards, the A-D bucket is designed to withstand wear, impacts, and continuous stress.
- Ease of use:** The intuitive design allows for easy use, even for less experienced operators. The side lock-unlock system is also easy to manage.
- Wide range of sizes:** Available from 200 liters to 15,000 liters, this bucket can be adapted to various crane sizes and material handling requirements.
- Environmental adaptability:** The galvanized version offers greater resistance to corrosion, making the A-D bucket suitable for more challenging environmental conditions. Meanwhile, the aluminum model, due to its light weight, allows maximum crane capacity utilization up to the tip.
- Maintenance:** The design of this bucket model makes maintenance virtually non-existent, leading to greater efficiency and reduced overall operational costs.
- Safety standards:** In addition to manufacturing standards, this bucket meets stringent safety regulations, helping ensure operator protection and compliance with local and international regulations.
- Customization:** Custom modifications can be requested to adapt the bucket to the specific needs of your site.
- Efficiency and productivity:** Using this bucket can greatly increase efficiency and productivity in your material handling projects on site. All buckets are designed, built, and subjected to rigorous quality tests in compliance with UNI EN ISO 12100, UNI EN 13854, ISO 8686, UNI EN 10027, and UNI EN 10204 standards. Each unit is equipped with a metal ID plate, a certificate of conformity, and a complete instruction manual for optimal use and maintenance. We are also proud to offer a one-year warranty on our products, in accordance with European directives, ensuring your long-term peace of mind and satisfaction.

Application sectors

 Construction