

DATA SHEET - TELESCOPIC SELF LEVELLING CRANE FORK WITH INTERNAL SPRINGS

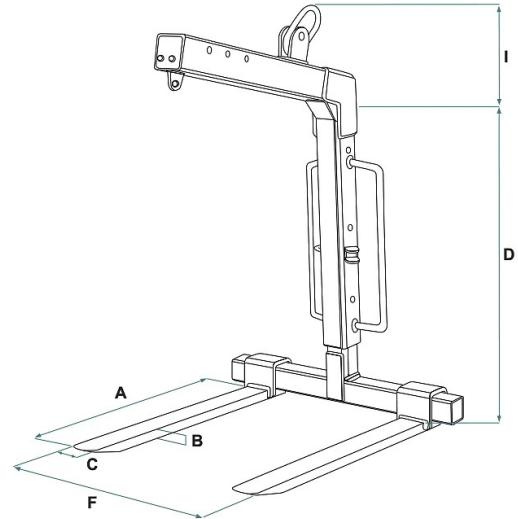

Code	Capacity (kg)	Weight (kg)	Dimensions (mm)					
			A	B	C	D	F	I
MBRA-15E	1500	155	1000	30	90	1155-1700	350-950	650
MBRA-20E	2000	170	1000	35	100	1155-1700	370-965	650
MBRA-25E	2500	220	1000	40	90	1280-1825	405-980	650
MBRA-30E	3000	255	1000	35	120	1280-1825	365-980	650

DATA SHEET - TELESCOPIC SELF LEVELLING CRANE FORK WITH INTERNAL SPRINGS

Crane forks



Telescopic self levelling crane fork with internal springs

Crane fork with internal spring automatic balancing

The MBRA-E telescopic crane fork represents an advanced solution for the efficient lifting and handling of pallets of various sizes. Its distinctive features include an adjustable height telescopic system, automatic balancing, and adjustable tines for greater versatility. Main features:

- 1. Height-Adjustable Telescopic System:** The crane fork is equipped with a height-adjustable telescopic system, allowing the lifting of pallets of different heights. This feature provides unparalleled flexibility during lifting operations and a compact height profile.
- 2. Automatic Balancing:** Automatic balancing is ensured by an integrated spring system that works in compression, ensuring optimal load balancing. This integrated spring system makes the crane fork ideal for use with both construction cranes and truck-mounted cranes, maintaining a compact height profile.
- 3. Adjustable Tines:** The crane fork is equipped with adjustable tines that allow the width of the fork to be adapted according to the size of the load. This feature makes the crane fork ideal for lifting loads of various sizes and shapes.
- 4. Robust Construction:** Made with high-quality materials, the crane fork is designed to ensure strength and durability. The sturdy structure can withstand heavy loads while maintaining reliable performance.
- 5. Ease of Use:** The crane fork is designed to be easily maneuverable, with large handles welded at the back that allow easy and quick insertion and removal of the fork from pallets.
- 6. All our crane forks come with a strap and ratchet in compliance with the EN13155 standard, ensuring safety and compliance with European lifting standards. They are also equipped with 2 welded perforated plates, which serve as a provision for the installation of a safety net. Finally, all crane forks are constructed and tested according to UNI EN ISO 12100, UNI EN 13854, ISO 8686, and UNI EN 10204 standards and come with the appropriate metal label, conformity certificate, and user and maintenance manual. All our products are covered by a one-year warranty (European Directive).**

Application sectors

 Construction  Lifting